

## Features

- 2:1 Wide input 4.5~75V DC
- Isolation Voltage: 1600V DC & 3000V - DC Depending on model
- Operating Temperature Range: -40~85°C
- Approved to cURus, UKCA, CE, RoHS, REACH
- Safety standards to IEC/EN/UL 62368-1
- Efficiency up to 84%
- EMC Class A & B Certified

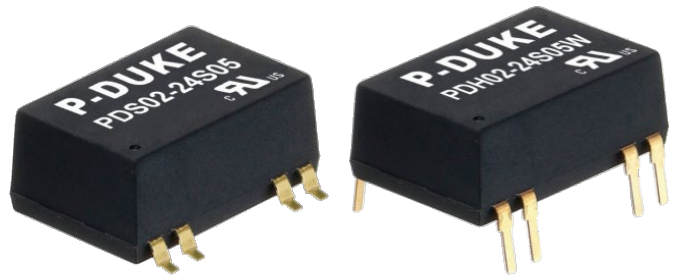

Ideal Power's 43PDS02-xyz 2W Series SMD, DIP DC/DC Converters are certified to cURus, UKCA, CE, RoHS, REACH & IEC/UL/EN 62368-1 Standards and comply with the relevant Efficiency Regulations. These are primarily used in ITE, Video & Audio Industries and customised solutions are available upon request.

### Part Number Structure

PDS02	-	48	S	05	H
Series Name		Output Power (VDC)	Output Quantity	Output Voltage (VDC)	Isolation Voltage (VDC)
<b>PDS:</b> SMD type		<b>05:</b> 4.5~9	<b>S:</b> Single	<b>3P3:</b> 3.3	<b>□:</b> Standard type
<b>PDH:</b> DIP type		<b>12:</b> 9~18		<b>05:</b> 5	<b>1600VDC</b> isolation
		<b>24:</b> 18~36		<b>09:</b> 9	<b>H:</b> 3000VDC isolation
		<b>48:</b> 36~75		<b>12:</b> 12	
			<b>D:</b> Dual	<b>15:</b> 15	
				<b>05:</b> <u>+5</u>	
				<b>12:</b> <u>+12</u>	
				<b>15:</b> <u>+15</u>	

**Models**

Model Number	Input Range VDC	Output Voltage VDC	Output current @ Full Load mA	Input Current @ No Load A	Efficiency %	Maximum Capacitor Load µF
43PDS(H)02-05S3P3	4.5~9	3.3	500	35	74	3300
43PDS(H)02-05S05	4.5~9	5	400	35	80	1680
43PDS(H)02-05S09	4.5~9	9	222	40	79	1000
43PDS(H)02-05S12	4.5~9	12	167	35	81	820
43PDS(H)02-05S15	4.5~9	15	134	40	83	680
43PDS(H)02-05D05	4.5~9	±5	±200	40	78	±1000
43PDS(H)02-05D12	4.5~9	±12	±83	40	81	±470
43PDS(H)02-05D15	4.5~9	±15	±67	40	82	±330
43PDS(H)02-12S3P3	9~18	3.3	500	20	75	3300
43PDS(H)02-12S05	9~18	5	400	20	81	1680
43PDS(H)02-12S09	9~18	9	222	20	79	1000
43PDS(H)02-12S12	9~18	12	167	20	81	820
43PDS(H)02-12S15	9~18	15	134	20	84	680
43PDS(H)02-12D05	9~18	±5	±200	25	78	±1000
43PDS(H)02-12D12	9~18	±12	±83	25	83	±470
43PDS(H)02-12D15	9~18	±15	±67	25	82	±330
43PDS(H)02-24S3P3	18~36	3.3	500	10	75	3300
43PDS(H)02-24S05	18~36	5	400	10	81	1680
43PDS(H)02-24S09	18~36	9	222	10	79	1000
43PDS(H)02-24S12	18~36	12	167	10	84	820
43PDS(H)02-24S15	18~36	15	134	10	84	680
43PDS(H)02-24D05	18~36	±5	±200	10	79	±1000
43PDS(H)02-24D12	18~36	±12	±83	10	84	±470
43PDS(H)02-24D15	18~36	±15	±67	10	84	±330
43PDS(H)02-48S3P3	36~75	3.3	500	7	75	3300
43PDS(H)02-48S05	36~75	5	400	7	81	1680
43PDS(H)02-48S09	36~75	9	222	7	79	1000
43PDS(H)02-48S12	36~75	12	167	7	82	820
43PDS(H)02-48S15	36~75	15	134	7	82	680
43PDS(H)02-48D05	36~75	±5	±200	7	78	±1000
43PDS(H)02-48D12	36~75	±12	±83	7	83	±470
43PDS(H)02-48D15	36~75	±15	±67	7	83	±330

**Input Specifications**

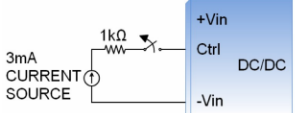
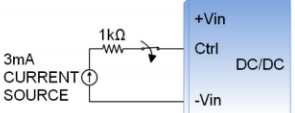
Parameter	Conditions		Min	Typ	Max	Unit
Operating input voltage range	05Vin(nom)		4.5	5	9	VDC
	12Vin(nom)		9	12	18	
	24Vin(nom)		18	24	36	
	48Vin(nom)		36	48	75	
Start-up time	Constant resistive load	Power up		5		ms
		Remote ON/OFF		5		
Input surge voltage	100 Second, max.	05Vin(nom)			15	VDC
		12Vin(nom)			25	
		24Vin(nom)			50	
		48Vin(nom)			100	
Input filter	Capacitor Type					
		DC_DC ON	Open or high impedance			
	Ctrl pin applied current via 1kΩ	DC_DC OFF	2	3	4	mA
		Remote off input current			2.5	mA
Application circuit DC-DC ON 						
DC-DC OFF 						

**Output Specifications**

Parameter	Conditions		Min	Typ	Max	Unit
Voltage accuracy			-1.0		+1.0	Watts
Line regulation	Low Line to High Line at Full Load		-0.2		+0.2	%
Load regulation	No Load to Full Load	Single	-1.0		+1.0	%
		Dual	-1.0		+1.0	
	10% Load to 100% Full Load	Single	-0.5		+0.5	
		Dual	-0.8		+0.8	
Cross regulation	Asymmetrical load 25%/100% FL	Dual	-5.0		+5.0	
Ripple and Noise	Measured by 20MHz bandwidth			30		mVp-p
Temperature coefficient			-0.02		+0.02	%/°C
Transient response recovery time	25% Load step change			250		μs
Short circuit protection						Continuous, automatic recovery

**General Specifications**

Parameter	Conditions		Min	Typ	Max	Unit
Isolation voltage	1 minute	Input to Output	1600		3000	V DC
Isolation resistance	500VDC		1			GΩ
Isolation capacitance					50	
					50	
Switching frequency	Full load to minimum load		100			kHz
Safety approvals	IEC/ EN/ UL62368-1					UL:E193009 CB:UL(Demko)
Weight						4.5g (0.16oz)
MTBF	MIL-HDBK-217F, Full load					7.137 x 10 <sup>6</sup> hrs

**Environmental Specifications**

Parameter	Conditions	Min	Typ	Max	Unit
Operating ambient temperature	Without derating	-40		+85	°C
	With derating	+85		+100	
Maximin case temperature				100	
Storage temperature range		-55		+125	°C
Thermal Shock					MIL-STD-810F
Vibration					MIL-STD-810F
Relative humidity					5% to 95% RH
Lead-free reflow solder process	Only for SMD type				IPC J-STD-020E
Moisture sensitivity level(MSL)	Only for SMD type				IPC J-STD-033C Level 2a

**EMC Specifications**

Parameter	Conditions	Level
EMI	EN55022 With external components	Class A, Class B
EMS	EN55024	
ESD	EN61000-4-2 Air ± 8kV and Contact ± 6kV	Perf. Criteria A
Radiated immunity	EN61000-4-3 10 V/m	Perf. Criteria A
Fast transient	EN61000-4-4 ± 2kV With an external input filter capacitor (Nippon chemi-con KY series, 220µF/100V)	Perf. Criteria A
Surge	EN61000-4-5 ± 1kV With an external input filter capacitor (Nippon chemi-con KY series, 220µF/100V)	Perf. Criteria A
Conducted immunity	EN61000-4-6 10 Vr.m.s	Perf. Criteria A
Power frequency magnetic field	EN61000-4-8 100A/m continuous; 1000A/m 1 second	Perf. Criteria A

**CAUTION:** This power module is not internally fused. An input line fuse must always be used.

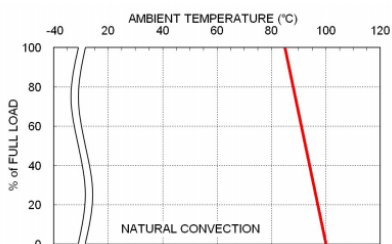
**Characteristic Curve**

43PDS02-48S05 Derating Curve

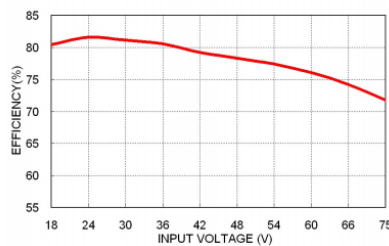

43PDS02-48S05 Efficiency vs. Input Voltage

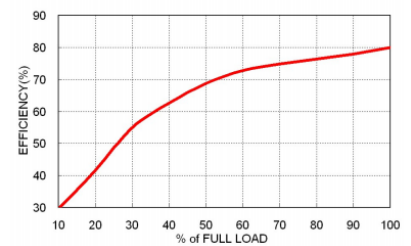

43 PDS02-48S05 Efficiency vs. Output Load

### Fuse Considerations

This power module is not internally fused. An input line fuse must always be used. This encapsulated power module can be used in a wide variety of applications, ranging from simple stand-alone operation to an integrated part of sophisticated power architecture. To maximum flexibility, internal fusing is not included; however, to achieve maximum safety and system protection, always use an input line fuse. The input line fuse suggest as below :

Model	Fuse Rating (A)	Fuse Type
43PDS(H)02-05S□□, 43PDS(H)02-05D□□	2	Slow-Blow
43PDS(H)02-12S□□, 43PDS(H)02-12D□□	1.5	Slow-Blow
43PDS(H)02-24S□□, 43PDS(H)02-24D□□	1	Slow-Blow
43PDS(H)02-48S□□, 43PDS(H)02-48D□□	1	Slow-Blow

### Mechanical Drawing

43PDS02

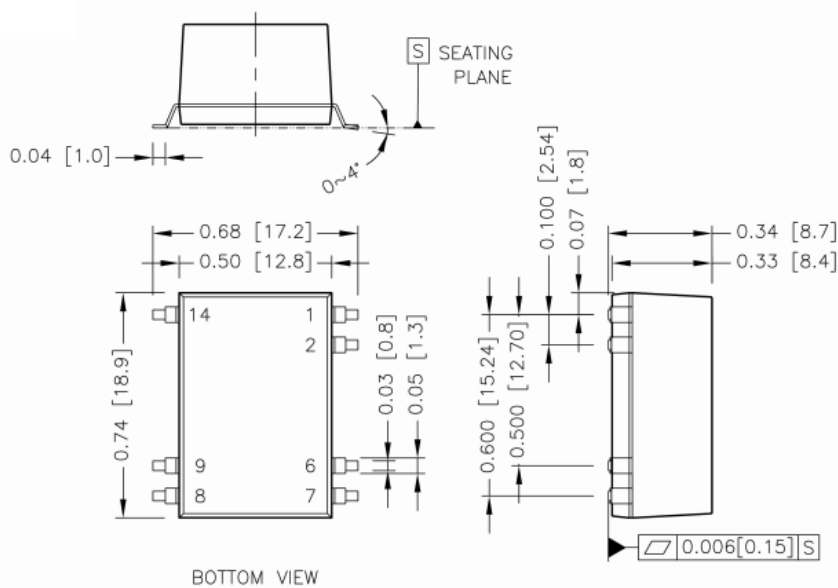

1. All dimensions in inch (mm)
2. Tolerance :x.xx±0.02 (x.x±0.5)  
x.xxx±0.01 (x.xx±0.25)
3. Pin pitch tolerance ±0.01 (0.25)
4. Pin dimension tolerance ±0.004(0.1)

### DIP Pin Connection

Pin	Single	Dual
1	-Vin	-Vin
2	Ctrl	Ctrl
6	NC	Common
7	NC	_Vout
8	+Vout	+Vout
9	-Vout	Common
14	+Vin	+Vin

**Mechanical Drawing**

43PDH02

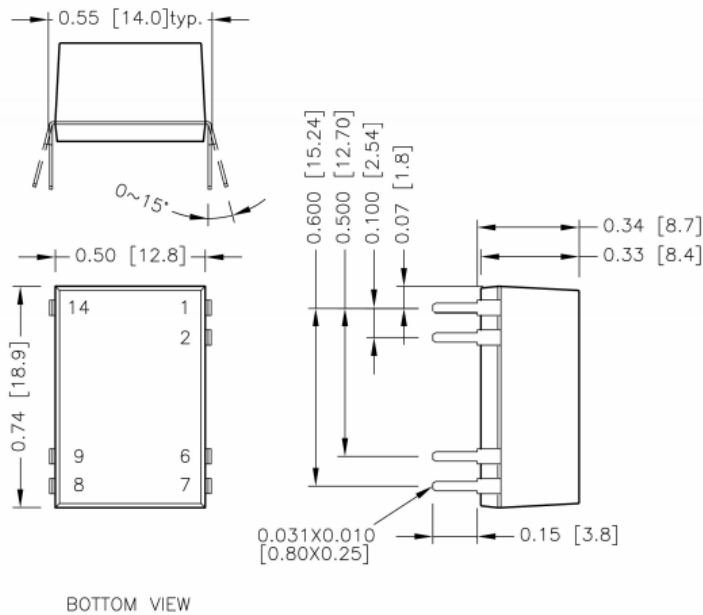

1. All dimensions in inch (mm)
2. Tolerance :x.xx±0.02 (x.x±0.5)  
x.xxx±0.01 (x.xx±0.25)
3. Pin pitch tolerance ±0.01 (0.25)
4. Pin dimension tolerance ±0.004(0.1)

**DIP Pin Connection**

Pin	Single	Dual
1	-Vin	-Vin
2	Ctrl	Ctrl
6	NC	Common
7	NC	_Vout
8	+Vout	+Vout
9	-Vout	Common
14	+Vin	+Vin

**Recommended Pad Layout**

43PDS02

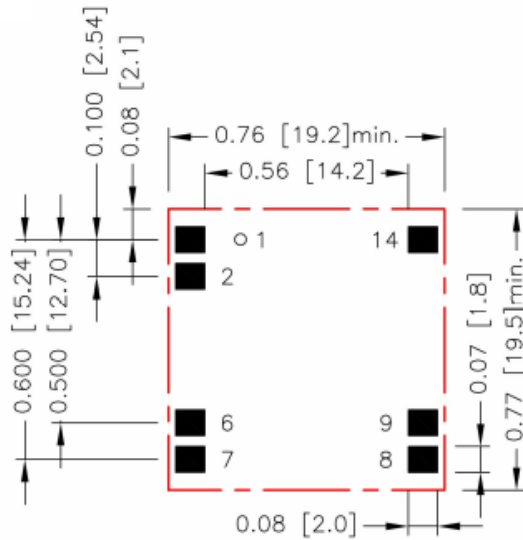

All dimensions in inch[mm]  
 Pad size(lead free recommended)  
 Top view pad:0.080x0.070[2.00x1.80]

43PDH02

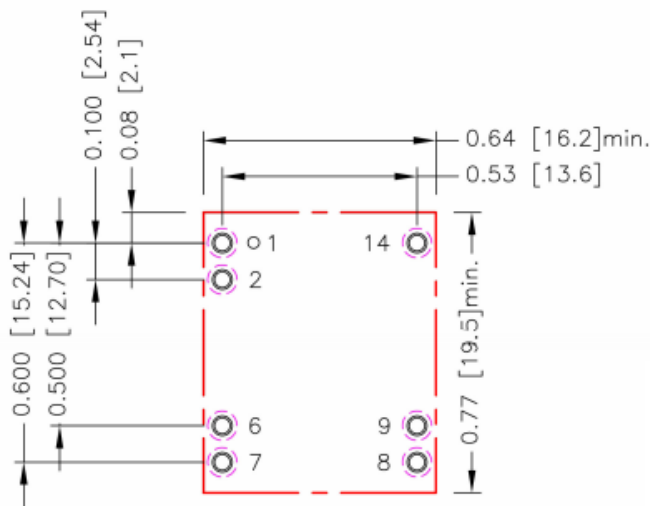

All dimensions in inch[mm]  
 Pad size(lead free recommended)  
 Through hole 1.2.6.7.8.9.14:  $\Phi$ 0.043[1.10]  
 Top view pad 1.2.6.7.8.9.14:  $\Phi$ 0.055[1.40]  
 Bottom view pad 1.2.6.7.8.9.14:  $\Phi$ 0.080[2.04]

**Thermal Considerations**

The power module operates in a variety of thermal environments. However, sufficient cooling should be provided to help ensure reliable operation of the unit. Heat is removed by conduction, convection, and radiation to the surrounding Environment. Proper cooling can be verified by measuring the point as the figure below. The temperature at this location should not exceed "Maximum case temperature". When Operating, adequate cooling must be provided to maintain the test point temperature at or below "Maximum case temperature". You can limit this Temperature to a lower value for extremely high reliability.

v Thermal test condition with vertical direction by natural convection (20LFM).

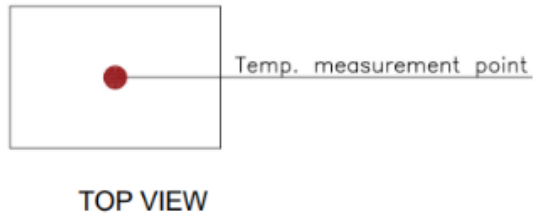

**Lead Free Reflow Profile (For SMD Type)**

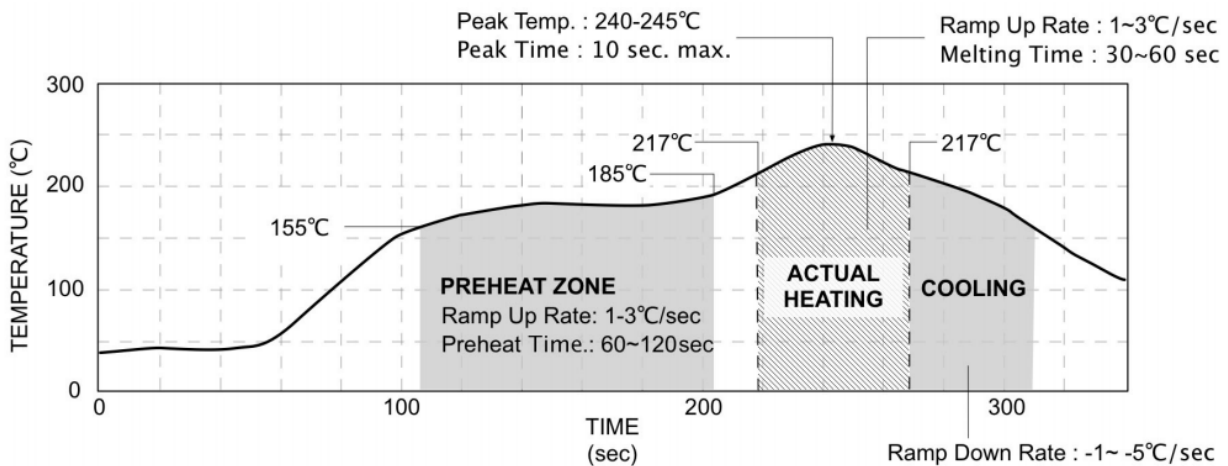

\*The curves define the maximum peak reflow temperature permissible measured on pin1 or Vin pin.